

AVAC

voice alarm system



wall-mounting modular
voice alarm system



WALL MOUNTING MODULAR VOICE ALARM SYSTEM

AVAC

AVAC is a new low-cost, high-quality modular voice alarm system designed to simplify the provision of a BS5839 part 8 compliant voice alarm system.

The fact that multiple AVACs (and slaves) can be connected to a fire detection system makes AVAC ideal not just for simple one zone installations but for virtually all small to medium sized applications, including phased evacuation projects.

With high quality pre-recorded digital messages, near CD-quality sound and ancillary connections for optional emergency microphones, public address and background music equipment, AVAC is particularly suited for factories, office blocks, shopping centres, hotels and leisure centres.

Suitable for category V1 and V2 systems complying with BS5839 part 8 (2008).



In one compact wall-mounting enclosure, AVAC comprises:-

- ▶ A straightforward fire alarm interface that can be connected to any analogue addressable fire alarm system via a series of input/output units on the loop
- ▶ An Apollo specific interface for direct connection to an XP95 or Discovery fire alarm loop
- ▶ A high-quality digital message store containing programmable Evacuate, Alert and Test messages
- ▶ A prioritised mixer
- ▶ Two x 60-Watt continuous average power Class D amplifiers (plus an optional standby amplifier)
- ▶ An EN54-4 compliant switch mode power supply and battery charger
- ▶ Three balanced line level inputs for the (optional) connection of an emergency microphone, paging/public address microphone(s) and a background music source
- ▶ Space for 2 x 7Ah VRLA batteries typically providing at least 24 hours standby and 30 minutes alarm running time
- ▶ A slave line level output allowing the connection of up to 26 slave AVAC amplifiers to extend loudspeaker coverage and allow greater flexibility over public address paging and background music distribution (as they have their own paging and background music inputs)

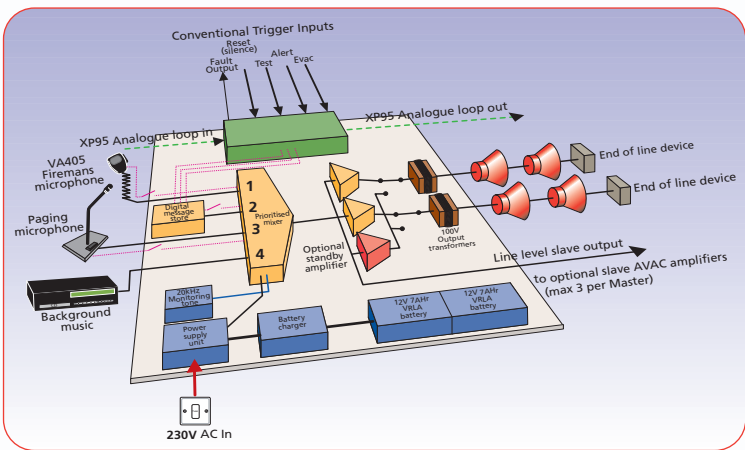

OPERATION

The principal function of AVAC is to generate clear voice messages to alert people to the presence of fire, normally under the control of a fire detection system. When AVAC receives a message trigger from the fire detection system, it responds by playing an appropriate message (Evacuate, Alert or Test) from its digital message store. This message is amplified and broadcast around the site via the system's loudspeakers. Three balanced line-level audio inputs are also provided for the connection of optional equipment such as an emergency microphone (to allow live directive announcements by the emergency services), public address paging equipment and a background music (BGM) source such as a CD player or radio tuner. The level of all four audio channels (digital message store, emergency mic., paging and BGM) can be set using four internal level controls. If multiple inputs and/or digital message triggers are active at the same time, AVAC's prioritized mixer ensures that only the most urgent audio signal is broadcast, as indicated below:-

Priority	Description
1	Emergency microphone
2	Evacuate, Alert or Test message (Evacuate overrides Alert, Alert overrides Test)
3	Paging / public address microphone(s)
4	Background music source(s)

AVAC'S FIRE ALARM INTERFACE

The host fire detection system can be connected to AVAC via three polarized, opto-isolated trigger inputs. These inputs are designed to control AVAC's digital message store and will activate when a steady voltage of 24V DC is applied to them.

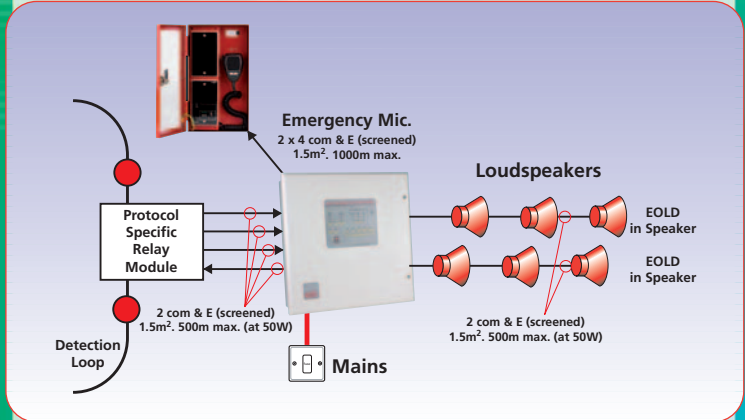

All inputs are prioritized according to the type of messages they trigger. AVAC can also be connected directly to any Apollo protocol XP95, Discovery or Xplorer analogue addressable fire alarm loop via its LOOP input. When connected in this way, AVAC emulates an Apollo sounder control module and must be addressed as such. Once addressed, AVAC responds to a fire panel's commands by activating its Evacuate message when it receives a continuous sounders command and its Alert message when it receives an intermittent sounders command. It also reports any fault conditions back to the analogue loop as a general fault allowing the fire detection system to announce the fault location accordingly.

MONITORING

In order to comply with current life safety standards, AVAC's loudspeaker lines, PSU, batteries, emergency microphone and

digital message store are all monitored for short circuits, open circuits, earth faults, discharge, disconnection and data corruption as appropriate. Non-critical inputs such as public address paging and background music are not monitored and, in the event of Mains failure, are automatically cut off to conserve battery life. This contributes to AVAC's efficient standby time - typically 24 hours (plus 30 minutes running time) using 2 x 7 Ah VRLA batteries. Provided the system is wired as recommended, an AVAC fault condition will be reported as a sounder fault on the fire detection system, with more detailed fault indication provided on the front of AVAC.

DIGITAL MESSAGE SELECTION

AVAC's digital messages are stored in MP3 format on a monitored, non-volatile memory card. The content of these can be adjusted to suit the application using a series of internal links. For example, the Evacuate message can be configured to state that 'a situation has arisen' or 'a fire has been reported' and to warn people - if appropriate - not to use the building's lifts.

AMPLIFIER AND LOUDSPEAKER CIRCUITS

AVAC is supplied with a minimum of two separate 60-Watt continuous average power Class D amplifiers. These are designed to drive AVAC's two loudspeaker circuits, each of which will accommodate up to 60 Watts of loudspeaker load (although 50 Watts is recommended to allow for system changes), through 100V line transformers, which step up the voltage for distribution around the site. An end-of-line device must be connected across the terminals of the last loudspeaker on each circuit and both circuits must be calibrated at commissioning using AVAC's calibrate button to ensure correct monitoring. Some AVACs feature an additional standby amplifier that will switch in if either of AVAC's regular amplifiers fail, a requirement of some life safety voice alarm specifications.

MULTIPLE AVACs AND SLAVE AMPLIFIERS

There is no limit to the number of master AVACs that can be used per system but the VA405 emergency microphone can be daisy-chained to a maximum of 26 master AVACs. For systems requiring more than one emergency microphone, up to four VA407 emergency microphones can be connected to a system. However this will reduce the number of AVAC masters that can be interlinked to 20 (for systems with two VA407s), 10 (for systems with three VA407s) and 6 (for systems with four VA407s).

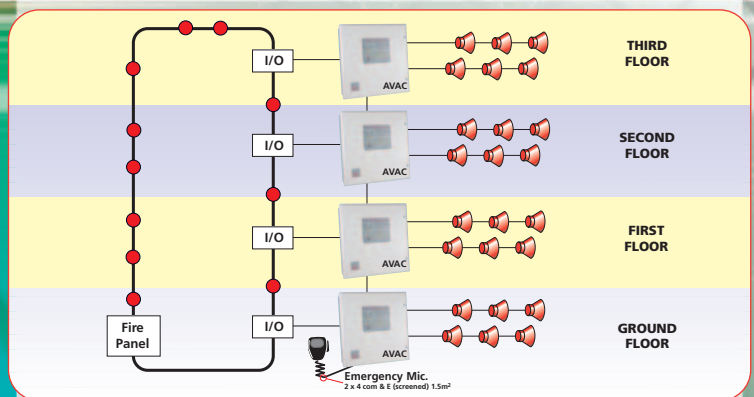

To increase audio coverage in large areas, up to 26 slave AVACs can be connected to one master AVAC. Slave AVACs repeat all emergency microphone and digital message broadcasts that are made at the master. They also feature their own paging and background music inputs meaning localized paging and background music can be easily implemented, a particularly useful feature for tenanted office block applications, etc.

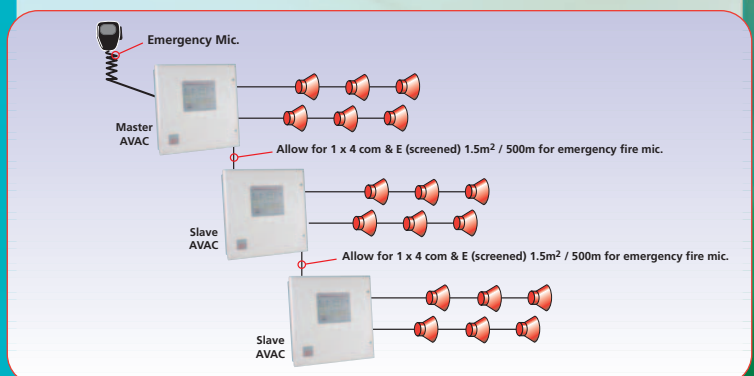

AVAC Voice Alarm System Technical Specifications

Power Supply & Charger

AC input	230 V a.c +/- 10% 50/60 Hz
Internal power supply	27 V d.c. Nominal
Max continuous output current limited to	5A @ 230 V a.c. (derate by 500 mA if batteries are charging)
Pulse peak output current limited to	7A @ 230 V a.c.
Supply & battery charger monitored for failure	YES (battery charger is also temperature compensated)
Batteries monitored for disconnection and failure	YES
Batteries protected against deep discharge	YES (Deep discharge cut off approx. 21 Volts)
Battery size and type	2 x 12 V 7 AHR VRLA connected in series
Mains fuse	240 V 1 A HRC ceramic 20 mm - compliant with IEC (EN60127 Pt2)
Battery fuse	5 A F 20 mm - compliant with IEC (EN60127 Pt2)
Max Battery Charge current	0.5 A

Inputs (Input level for 100 V RMS (1 kHz tone) with gain adjust set to Max. sensitivity)

BGM	230 mV RMS
BGM with link	2.3 V RMS
Page	230 mV RMS
Page with link	2.3 V RMS
Emgcy Mic input	230 mV RMS
Page PTT Volt Free contacts non triggered state	Open circuit
Page PTT Volt Free contacts triggered state	Closed circuit
Emgcy Mic PTT non triggered state	6K8
Emgcy Mic PTT triggered state	1K in parallel with 6K8
Manual inputs M1,M2,M3,RES	12 V 1mA to 25 V 2.5 mA (optically isolated)

Outputs

Max Output AUX 24 V (Master only)	100 mA
Max Output Emgcy Mic 24 V	100 mA
Max Speaker Output	100 V 0.6 A RMS (60 W) x 2
Output power	2 x 60 W continuous average power
Output Frequency response at 30 W load / line driven from the Emgcy Mic	152 Hz to 12 kHz (220 Hz to 6.2 kHz on Page and BGM)
Fault output relay single pole changeover	1A 30 V
Loudspeaker Monitoring Tone	20 kHz

Battery calculations

Average standby current at full load	97 mA
Average alarm current at full load (audio on Emgcy Mic)	1.2 A (AUX and Emgcy Mics will add to the current drain requirements)

Order Codes

VA403	Master AVAC dual 60W continuous average power amplifier, charger & PSU includes fire alarm interface, emergency mic, paging & BGM connections
VA403H	Master AVAC dual 60W continuous average power amplifier, charger & PSU c/w 'hotswap' standby amp. includes fire alarm interface, emergency mic, paging & BGM connections
VA402	Slave AVAC dual 60W continuous average power amplifier, charger & PSU (max 26 per master AVAC) includes local paging & BGM connections
VA402H	Slave AVAC dual 60W continuous average power amplifier, charger & PSU (max 26 per master AVAC) c/w 'hotswap' standby amp, includes local paging & BGM connections
VA405	Emergency microphone (max. 1 per system). Limits the number of Master AVACs that can be daisy-chained to 26
VA407	Emergency microphone (2 to 4 per system). 2 x VA407s limits the number of Master AVACs to 20, 3 x VA407s to 10 and 4 x VA407s to 6.
VA406	Line level paging microphone (max. 1 per system)
VA406X	Line level paging microphone (up to 4 per system)
VA421A	6" 6W ceiling speaker c/w steel fire-dome & ceramic terminal block
VA422A	8W wall mounting metal cabinet speaker c/w ceramic terminal block
VA423	8W wall mounting bi-directional metal speaker c/w ceramic terminal block
VA428	30W pendant loudspeaker c/w 8m cable and internal stress wire (requires VA490 or VA492)
VA430	6W round wall/ceiling speaker in metal cabinet c/w ceramic terminal block
VA490	Ceramic terminal block and thermal fuse assembly (use to convert wire-end sealers to BS5839-8, needs adaptable back box)
VA492	VA loudspeaker metal termination box c/w 2 x ceramic terminal blocks and thermal fuses



Tel: 0844 800 1625 (UK callers)

Tel: +44 (0)191 417 4551 (Overseas)

Fax: 0191 417 0634.

Email: info@signet-ac.co.uk